

Top view
Scale: 3:1

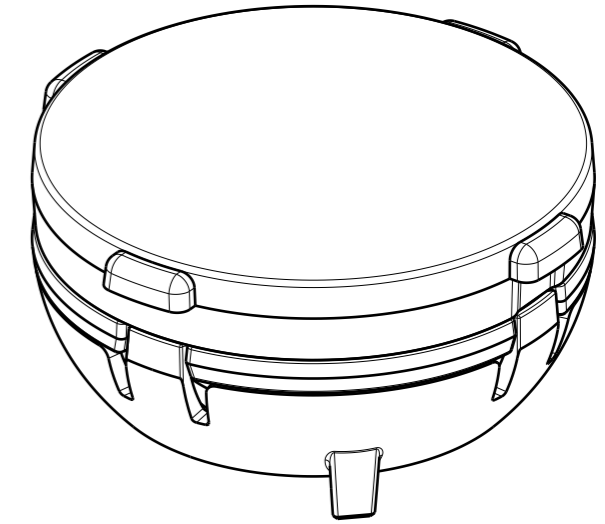

Section view A-A
Scale: 3:1

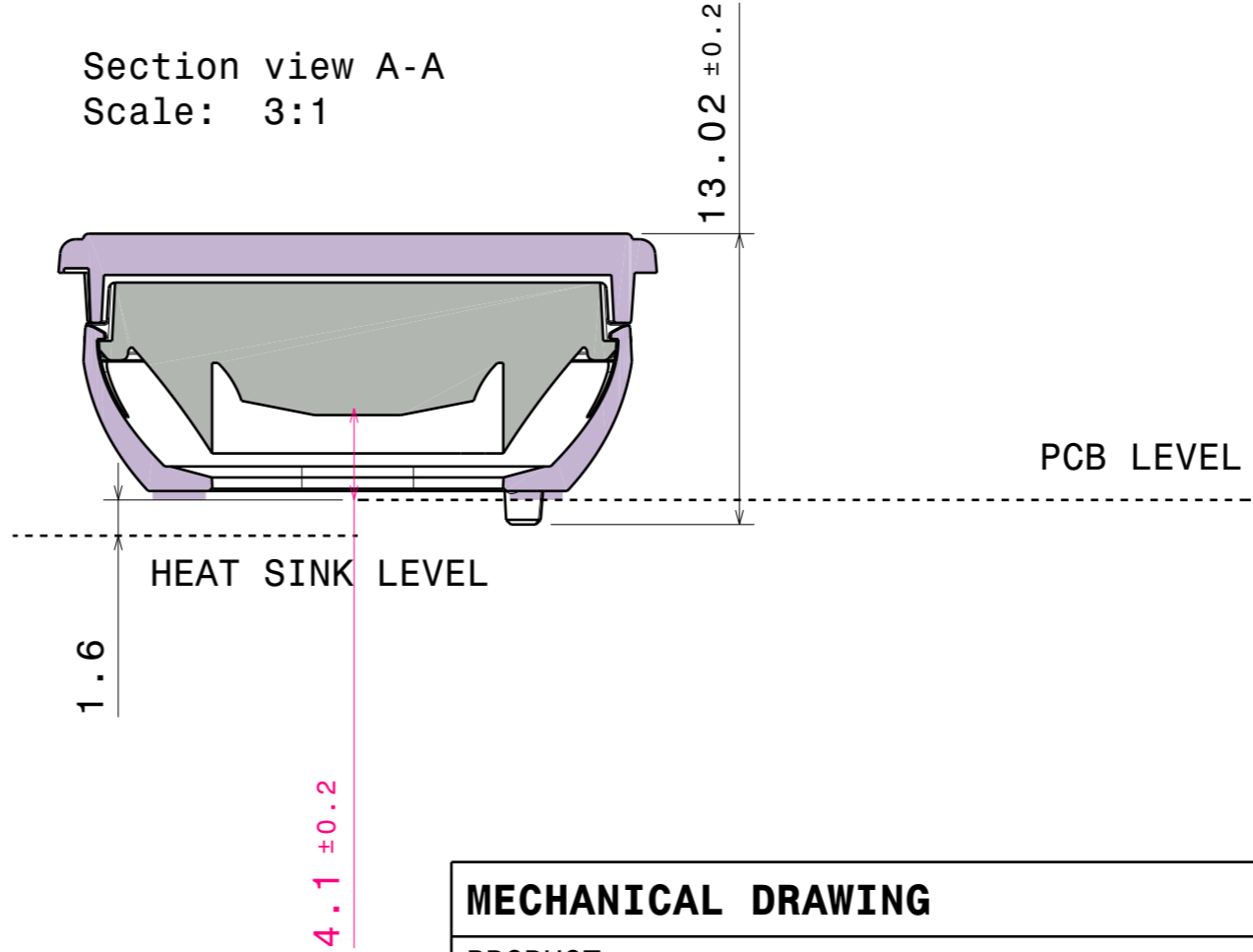

| BEAM | ROTATION |
|------|----------|
| S | 0 |
| M | 11,25 |
| W | 22,5 |

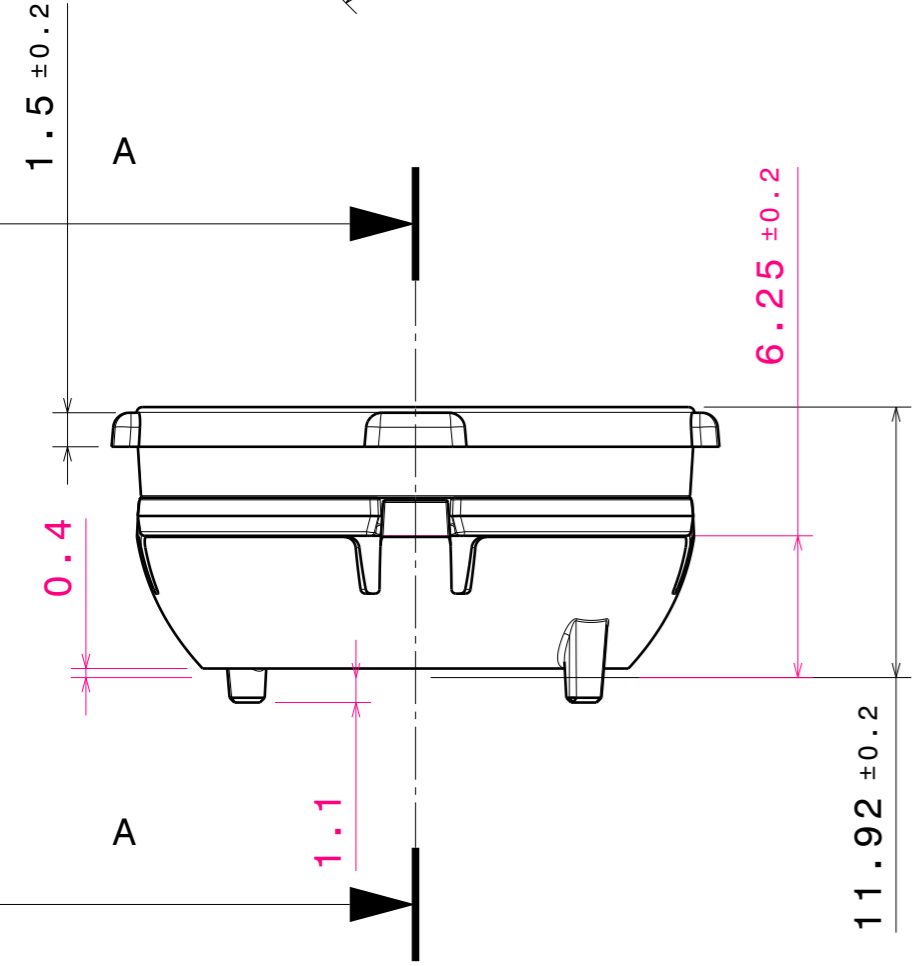

Notes

- PCB or heatsink level.
- LED location

Ensure LED fitting from a product specific 3D model available from www.ledil.com

For more details about installation please see LEDiL Installation Guide on www.ledil.com

| MECHANICAL DRAWING | | LEDiL |
|--|-----------------------------|---|
| PRODUCT | AMY - ZOOM | |
| Plastic moulding general tolerances according to DIN 16901-130 and applies if not otherwise shown in the drawing. Silicone moulding general tolerances according to ISO 3302-1 Class M3 and applies if not otherwise shown in the drawing. | FIRST ANGLE PROJECTION: | This drawing is the property of LEDiL Oy. It may not be copied or otherwise distributed without prior written permission from LEDiL Oy. |
| SCALE | 1:1 | WEIGHT 8,444g |
| | | A3 SHEET 1/1 |